

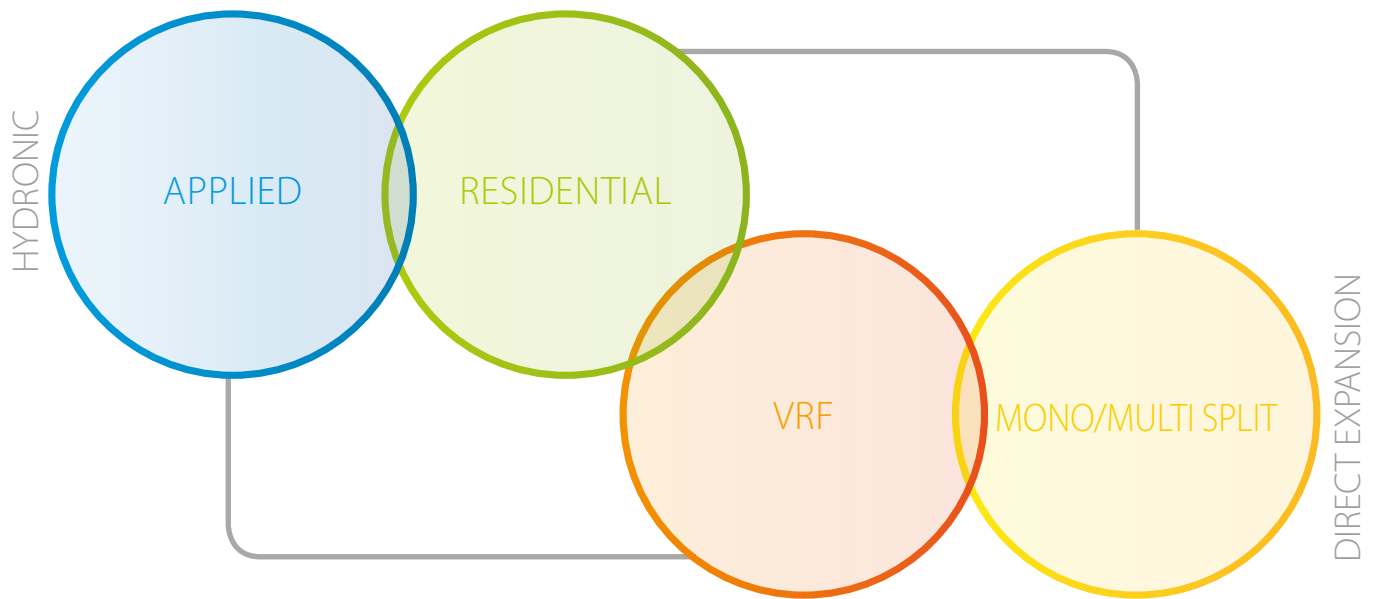

ELFOEnergy Edge EVO
Inverter heat pump
air cooled
for outdoor installation



Clivet. Change things



Solutions to ensure sustainable comfort and the well-being of people and the environment

In 30 years of working on the design, manufacturing and distribution of air conditioning and handling systems, combining high efficiency with minimal environmental impact, Clivet has developed solutions to ensure sustainable comfort and the well-being of people and the environment.

Designing and developing year-round air conditioning solutions with innovative technologies are part of Clivet's DNA, which means the company has always been ready for the future.





New hydronic range ELFOEnergy EVO R-32



5 kW

ELFOEnergy Edge EVO R-32



ELFOEnergy Sheen EVO R-32



90 kW

ELFOEnergy Storm EVO R-32

Features and applications

ELFOEnergy Edge EVO heat pumps are high efficiency packaged units for residential and light commercial applications. Designed for outdoor installation, they ensure the highest energy efficiency over the entire operating cycle.

In addition to the standard components, they offer as an option:

- inertial storage tank underneath the unit
- 3-way valve for domestic hot water
- domestic hot water tank
- back-up heater for additional heating capacity
- hose kit for hydraulic connections

DC Inverter compressor

Twin rotary DC Inverter compressor with permanent magnet brings quality, reliability, high performances at partial loads and a particularly silent operation. In fact, it is installed on anti-vibration mounts and it is wrapped in a special sound-absorbing hood.

The full-DC frequency conversion system dramatically reduces the energy consumption by more than 30%.

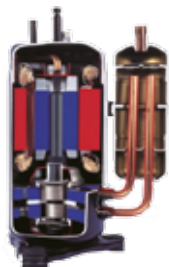

DC Inverter fan

DC brushless fan motors help to meet heating and cooling demands with low noise emission and low power consumption.

Both fans and fan guards are designed with CFD technology, ensuring silent and highly efficient operation.



Hydrophilic coil

External exchanger is made by:

- inner threaded copper pipes that optimise the heat exchange efficiency
- aluminum fins

Hydrophilic treatment allows the correct evacuation of condensing water and largely prevents ice formation.



Hydronic Module

Integrated hydronic module with DC circulation pump, expansion vessel and water flow switch. These hydraulic components are already included in the unit to guarantee:

- High reliability
- Space reduction
- Quicker and easier maintenance of the hydraulic circuit



Control

New generation wired user interface offers a complete control solution, thanks to the function keys, the graphic display and the multilevel menu.

The remote control and the integrated thermostat further simplify the unit management.



High energy efficiency

The new DC inverter systems forms a full DC frequency conversion system that allows to dramatically reduce the power consumption by more than 30%.

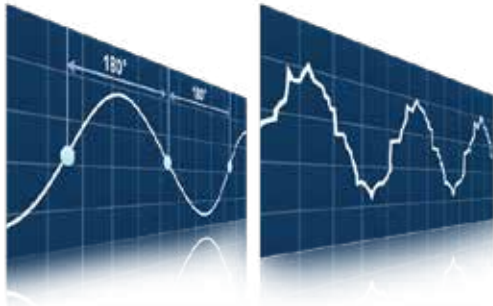

Smooth 180° sine wave, operation efficiency is improved by almost 30%

Conventional saw tooth wave, low operation efficiency

Constant temperature level, higher comfort

Thanks to the DC inverter technology, the rotary speed of compressor is precisely controlled according to the energy demand of the plant. The set temperature remains stable which guarantees greater comfort for the user.

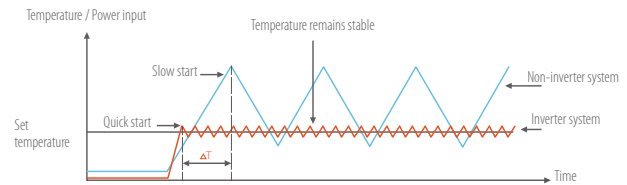

Start-up

• Quick start-up

The inverter system supplies power according to the energy demand by adjusting motor rotary frequency, so it is possible to achieve comfort conditions in less time than a system without inverter and the start-up time is reduced.

• Less frequent start/stop

The inverter technology ensures fewer start/stop cycles. This obviously expands compressor's lifespan and reduces sharp noise.

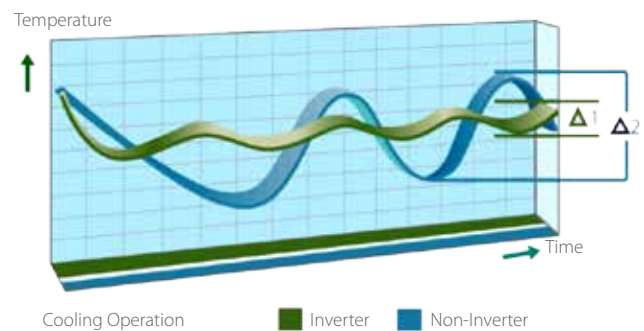

Full DC Inverter Technology

ELFOEnergy Edge EVO is the new energy reference for heat pumps. The inverter system precisely adjusts the rotation frequency of the compressor according to the energy demand, offering:

- Reduced start-up time
- Comfort conditions are achieved in less time than a system without inverter
- Lower levels of temperature fluctuation during operation

ErP compliant

ELFOEnergy Edge EVO is compliant with the ErP (Energy Related Products) European Directive. It includes the Commission delegated Regulation (EU) No 811/2013 (rated heat output ≤ 70 kW at specified reference conditions) and the Commission delegated Regulation (EU) No 813/2013 (rated heat output ≤ 400 kW at specified reference conditions)

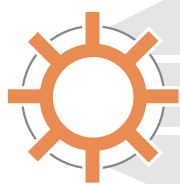

Class in heating

A

ErP Class (Low Temperature)

A+++*

ErP Class (Medium Temperature)

A++

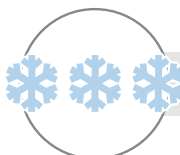

SEER

4,99

* Energy efficiency class A+++ (range from A+++ to D) will be available from September 26th 2019; therefore, until that date the class A++ (range from A++ to G) must be considered as current standard.

R-32

- Ecological refrigerant with a GWP (Global Warming Potential) of -70% compared to R-410a
- Better performance under severe conditions
- Less charged volume is needed in the system
- Higher coefficient on heat transfer



Tax Credit

Due to its high efficiency, ELFOEnergy Edge EVO may be eligible for heat pump subsidies in Your Country



Advantages of seasonal efficiency

For most of the time the heat pump operates to meet half of the thermal load required by the building. Consequently, unit efficiency is no longer given by a single working point, but from seasonal efficiency.

ELFOEnergy Edge EVO not only complies with the ErP Directive, but exceeds 50% the minimum requirements of the European Directive:

- Seasonal efficiency: SCOP in A++ Class (A7/W55°C)
- Very high performances even in cooling: SEER 4.99 makes the heat pump comparable to a chiller

Extended operation range

ELFOEnergy Edge EVO offers complete solution to any needs requested by the plant, being able to operate in heating, cooling and domestic hot water mode.

In all operating modes, wide operation ranges are guaranteed both in terms of outdoor air temperature and supply water temperature.

Compressor and heat exchangers are sized only to guarantee the best performances. For example, they allow to supply a heat capacity of 80% at -7°C .

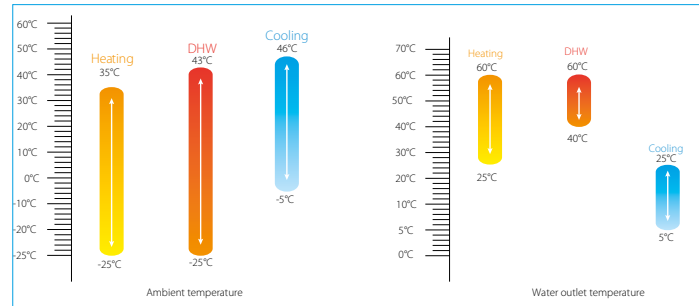

Domestic hot water production

ELFOEnergy Edge EVO heat pumps can produce domestic hot water up to an outdoor temperatures of -25°C .

The temperature of the water produced can reach 60°C even during summer when outdoor temperatures reach 30°C .

This allows to use heat pumps throughout the year and to be perfectly adapt either to configurations of systems with radiant panels and terminal units or to new or renovated buildings.

To ensure a better production efficiency and therefore to reduce operation costs, thanks to the experience on the monitored systems, Clivet recommends to define the set point of the domestic hot water between $48-50^{\circ}\text{C}$.



Main features maximum quietness, extended operating range and DHW production

The particular constructive features of ELFOEnergy Edge EVO, beyond increasing the efficiency of the unit, minimize the sound level making it particularly silent.

Applications that require great attention to sound levels find an answer to their needs in the 2 additional acoustic configurations of this series:

- Silenced: sound levels are reduced by -3 dB
- Super-silenced: sound levels are reduced by -5 dB

Sound level data of the two silenced acoustic configurations are available in the technical bulletin.

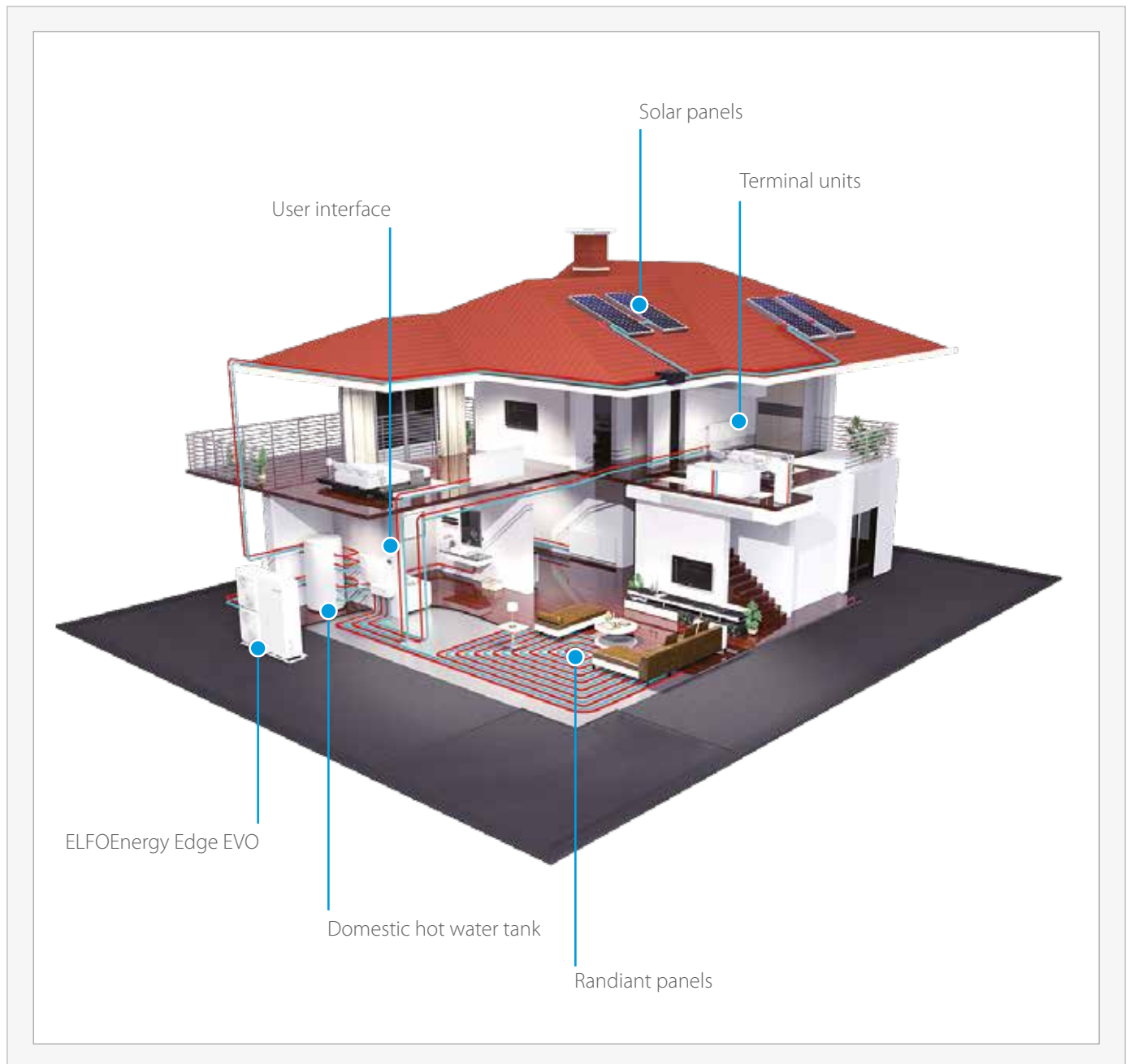

Flexibility

ELFOEnergy Edge EVO is an integrated system that heats and cools space, as well as produces domestic hot water. It offers total comfort solution all year round. The system can completely replace the traditional gas or fuel boilers, but it is also able to work together with them.

To guarantee the maximum flexibility, ELFOEnergy Edge EVO can be combined together with:

- floor heating coils
- low temperature radiators
- terminal units
- domestic hot water tank
- mixed systems

It is also compatible with auxiliary heat source such as solar energy and boiler.

Technical Data



Size - W SAN-YMI			21	31	41	61	71	81
230/1/50	▶ Cooling capacity (EN14511:2013)	(1) kW	4,85	6,3	7,95	10,9	12,9	13,8
230/1/50	Total power input (EN14511:2013)	(1) kW	1,63	2,27	3,14	3,73	4,64	5,21
230/1/50	EER (EN 14511:2013)	(1) -	2,98	2,77	2,53	2,92	2,78	2,65
230/1/50	SEER	(4) -	4,71	4,99	4,92	4,85	4,73	4,54
230/1/50	▶ Heating capacity (EN14511:2013)	(2) kW	4,80	6,70	8,60	12,4	14,1	16,2
230/1/50	Total power input (EN14511:2013)	(2) kW	1,33	1,88	2,50	3,51	4,06	4,72
230/1/50	COP (EN 14511:2013)	(2) -	3,60	3,57	3,44	3,53	3,47	3,43
230/1/50	Water flow-rate (User Side)	l/s	0,23	0,3	0,35	0,52	0,62	0,66
230/1/50	Useful pump discharge head	kPa	60,6	50,7	37,8	49,65	36,4	30,7
230/1/50	Sound pressure level	(3) dB(A)	49	52	55	54	55	56
230/1/50	Refrigeration circuits					1		
230/1/50	No. of compressors					1		
230/1/50	Type of compressors					TWIN ROTARY INVERTER DC		
230/1/50	Standard airflow		850	850	850	1710	1710	1710
Directive ErP (Energy Related Products)								
230/1/50	ErP Energy Class - AVERAGE Climate - W35	(5)	A+++	A+++	A+++	A++	A++	A++
230/1/50	ErP Energy Class - AVERAGE Climate - W55		A++	A++	A++	A++	A++	A++
230/1/50	SCOP - AVERAGE Climate - W35	(4)	4,48	4,49	4,51	4,3	4,35	4,3
230/1/50	SCOP - AVERAGE Climate - W55	(4)	3,23	3,24	3,22	3,23	3,26	3,27

Size - W SAN-YMI			61	71	81
400/3/50+N	▶ Cooling capacity (EN14511:2013)	(1) kW	10,9	12,9	13,8
400/3/50+N	Total power input (EN14511:2013)	(1) kW	3,72	4,61	5,19
400/3/50+N	EER (EN 14511:2013)	(1) -	2,93	2,8	2,66
400/3/50+N	SEER	(4) -	4,85	4,73	4,54
400/3/50+N	▶ Heating capacity (EN14511:2013)	(2) kW	12,4	14,1	16,2
400/3/50+N	Total power input (EN14511:2013)	(2) kW	3,45	3,98	4,70
400/3/50+N	COP (EN 14511:2013)	(2) -	3,59	3,54	3,45
400/3/50+N	Water flow-rate (User Side)	l/s	0,52	0,62	0,66
400/3/50+N	Useful pump discharge head	kPa	49,7	36,4	30,7
400/3/50+N	Sound pressure level	(3) dB(A)	54	56	56
400/3/50+N	Refrigeration circuits			1	
400/3/50+N	No. of compressors			1	
400/3/50+N	Type of compressors			TWIN ROTARY INVERTER DC	
400/3/50+N	Standard airflow		1710	1710	1710
Directive ErP (Energy Related Products)					
400/3/50+N	ErP Energy Class - AVERAGE Climate - W35		A++	A++	A++
400/3/50+N	ErP Energy Class - AVERAGE Climate - W55		A++	A++	A++
400/3/50+N	SCOP - AVERAGE Climate - W35	(4)	4,30	4,35	4,30
400/3/50+N	SCOP - AVERAGE Climate - W55	(4)	3,23	3,26	3,27

- Note**
- Data calculated in compliance with Standard EN 14511:2013 referred to the following conditions: Internal exchanger water temperature = 12/7°C; Entering eExternal exchanger air temperature = 35°C
 - Data calculated in compliance with Standard EN 14511:2013 referred to the following conditions: Internal exchanger water temperature = 40/45°C. External exchanger air temperature 7 D.B. /6 (°C) W.B.
 - The sound levels refer to the unit at full load, in the rated test conditions. The sound pressure level refers to a distance of 1m from the external surface of the units operating in an open field. Measures according to UNI EN ISO 9614-2 regulations, with respect to the EUROVENT B/1 certification. Data referred to the following conditions: Internal exchanger water = 12/7°C; Outdoor air temperature 35°C
 - Data calculated according to the EN 14825:2016 Regulation
 - Energy efficiency class A+++ (range from A+++ to D) will be available from September 26th 2019; therefore, until that date the class A++ (range from A++ to G) must be considered as current standard.
- The Product is compliant with the Erp (Energy Related Products) European Directive. It includes the Commission delegated Regulation (EU) No 811/2013 (rate heat output ≤70 kW at specified reference conditions) and the Commission delegated Regulation (EU) No 813/2013 (rated heat output ≤400 kW at specified reference conditions).
- 230/1/50 Supply voltage 230/1/50
400/3/50+N Supply voltage 400/3/50+N

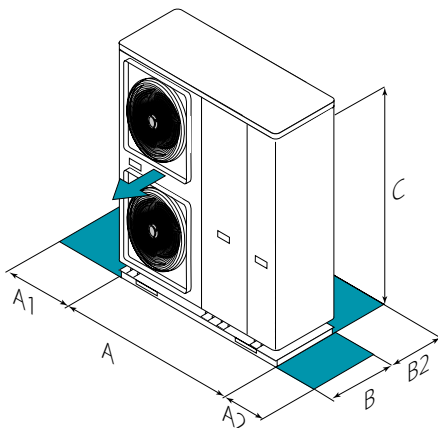

Size - W SAN-YMI		21	31	41	61	71	81
A - Length	mm	1210	1210	1210	1404	1404	1404
B - Width	mm	402	402	402	405	405	405
C - Height	mm	945	945	945	1414	1414	1414
A1	mm	400	400	400	400	400	400
A2	mm	400	400	400	400	400	400
B2	mm	600	600	600	1100	1100	1100
230/1/50	Operating weight	kg	92	92	158	158	158
400/3/50+N	Operating weight	kg	111	111	178	178	178

The above mentioned data are referred to standard units for the constructive configurations indicated. For all the other configurations, refer to the relative Technical Bulletin.

230/1/50 Supply voltage 230/1/50
400/3/50+N Supply voltage 400/3/50+N

CAUTION! For trouble-free operation of the unit it is essential to maintain the clearances in green.

**CLIVET SPA**

Via Camp Lonc 25, Z.I. Villapaiera - 32032 Feltre (BL) - Italy
Tel. + 39 0439 3131 - Fax + 39 0439 313300 - info@clivet.it

CLIVET GROUP UK Limited

4 Kingdom Close, Segensworth East - Fareham, Hampshire - PO15 5TJ - United Kingdom
Tel. + 44 (0) 1489 572238 - Fax + 44 (0) 1489 573033 - enquiries@clivetgroup.co.uk

CLIVET GROUP UK Limited (Operations)

Units F5&F6 Railway Triangle Ind Est, Walton Road - Portsmouth, Hampshire - PO6 1TG - United Kingdom
Tel. +44 (0) 2392 381235 - Fax. +44 (0) 2392 381243 - service@clivetgroup.co.uk

CLIVET ESPAÑA S.A.U.

C/ Bac de Roda, 36 - 08019 Barcelona - España
Tel: +34 93 8606248 - Fax +34 93 8855392 - info@clivet.es

Av.Manoteras Nº 38, Oficina C303 - 28050 Madrid - España
Tel. +34 91 6658280 - Fax +34 91 6657806 - info@clivet.es

CLIVET GmbH

Hummelsbütteler Steindamm 84, 22851 Norderstedt - Germany
Tel. + 49 (0) 40 32 59 57-0 - Fax + 49 (0) 40 32 59 57-194 - info.de@clivet.com

CLIVET RUSSIA

Elektrozavodskaya st. 24, office 509 - 107023, Moscow, Russia
Tel. + 74956462009 - Fax + 74956462009 - info.ru@clivet.com

CLIVET MIDEAST FZCO

Dubai Silicon Oasis (DSO), High Bay Complex, Office N. 20, PO BOX 342009, Dubai, UAE
Tel. + 9714 3208499 - Fax + 9714 3208216 - info@clivet.ae

CLIVET AIRCONDITIONING SYSTEMS PRIVATE LIMITED

501/502, Commercial-1, Kohinoor City, Old Premier Compound, Kirol Road, Off L B S Marg, Kurla West - Mumbai 400 070 - India
Tel. +91 22 30930250 - info.in@clivet.com

www.clivet.com
www.clivetlive.com

A Group Company of

